

Valvsys, LLC T1 Modulating (Servo) Electric Actuator Use and Care Manual - DC

1. INTRODUCTION

The T1 Modulating electric actuator by Valvsys, LLC brings the latest technology in valve positioning. The modulating control card allows the actuator to be positioned intermediate of full open/close. Either a 4-20mA or 0-10Vdc input signal allows complete control over the position of the valve. The actuator responds linearly to changes in input. Thus the valve is rotated in a direct proportion to a change in the input signal. Local on board switches mean that the user can move the valve to the desired set up positions without having to have a handheld control source. Once in position these settings are stored digitally into the microprocessor. Having the microprocessor means no trim pots to adjust and allows for control problems such as a blocked valve by shutting down and sending alarm signals to the control room preventing further problems.

Note: this manual is for the Calibration Use and Care of the T1 Servo card. For the Use and Care of the valve actuator see the specific bulletin pertaining to that model such as B00031 for the EV series and B00039 for the NV series, etc. These manuals can be obtained from contacting Valvsys or visiting our web-site at www.valvsys.com.

2. FEATURES

The Valvsys T1 Modulating control card has many features that make it state of the art. Some of these features are:

- Digital setup
- Microchip 8bit microprocessor with flash memory (retains software nearly indefinitely)
- 10bit Analog to Digital converter chip
- Concurrent processor algorithm with interrupt routine
- Pushbutton Local Control (Mode, Jog Hi, Jog Lo, Enter, Reset)
- 10amp relay contact for motor input
- 10amp relay contact for alarm signal output (excessive cycling, failure to reach position, etc.)
- UL508/CSA high voltage trace design
- 48 pitch precision feedback potentiometer gears
- 115Vac - 12/24Vdc power versions available
- 4-20Ma - 0-10Vdc input jumper select
- RS232 serial port header
- 30° to 180° rotational operating range
- Potentiometer mounting complete with clutch (allows 360° rotation before final span is set)

3. INPUT OPTIONS

The input jumper S2 must be set according to the input type selected. Note a loss of signal will drive the unit to the low signal position. The unit must be re-calibrated for reverse

	Signal	Jumper Position
Current (250 ohm shunt)	4-20mA	Right two posts
Voltage	0-10Vdc	Left two posts

acting to drive to the high position on loss of signal.

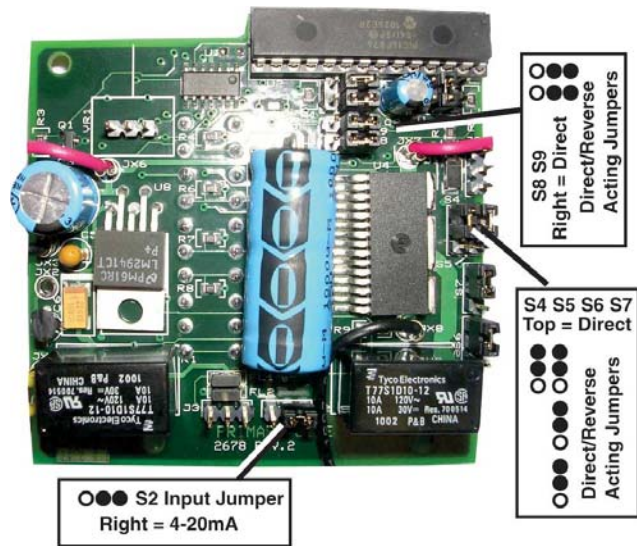

4. DIRECT / REVERSE ACTION

Jumpers set the action of the actuator. The unit is set at the factory for direct acting where the unit drives in a CW rotation upon receiving a low signal, i.e. 4mA = CW. The rotation is viewed from the top of the unit. However, moving the jumpers can set the unit to drive CCW upon receiving a low signal (reverse acting).

T1 MODULATING (SERVO) USE AND CARE

Action	Rotation	Setting
Direct Acting	4mA = CW 0Vdc = CW	jumpers S4, S5, S6, S7 on top two posts jumpers S8, S9 on right two posts
Reverse Acting	20mA = CW 10Vdc = CW	jumpers S4, S5, S6, S7 on bottom two posts jumpers S8, S9 on left two posts

5. SET-UP (CALIBRATION)

1. Verify that the actuator and valve move freely. Any travel stops should be removed or the actuator should be positioned to operate within those stops by rotating the manual override or by mounting the actuator in that arrangement.
2. Make sure the "safety overtravel" switches are adjusted out of the required span. See 7 Safety Overtravel.
3. Connect the input signal to terminals 6,7 and 8. Note the position of the input Jumper S2 and select the appropriate position corresponding to your input. 4-

the unit will drive to the factory set position corresponding to the input signal given. Simply touch the Local / Remote switch to stop the unit. The local / Alarm LED will light. The unit can now be positioned using the Jog Hi and Jog Lo buttons. Jog Hi means the unit rotates to the 20mA (or 10Vdc) direction. Jog Lo means the unit rotates to the 4mA (or 0Vdc) direction.

5. Push and hold the Jog Hi button to drive the unit to the desired end of travel position. Drive a little past the desired position (approximately 5°) and then use the Jog Lo to come back to the set point. Once the unit is there press and hold the enter button. While holding Enter press the Jog Hi button. The Jog Hi LED will flash. The position is now stored in memory.
6. Now, drive the unit to the Lo position. Once again press and hold the Enter button. Then touch the Jog Lo button simultaneously. The Jog Lo LED will flash indicating that it has been stored.
7. Touch the Local / Remote button. The Local / Alarm LED goes off and the unit rotates to the corresponding input signal.

6. SPAN 90°, 180°

Typically the actuator is set for 90° of span (4mA = 0° to 20mA = 90° rotation). However, the T1 modulating control card can be set up for any degree of span from 30° to 180°. There is no need to set any jumpers. Simply follow the steps in 5. Set-Up above and drive the unit to the span that is desired between 30° and 180°.

7. SAFETY OVERTRAVEL SWITCHES

The unit has two "safety overtravel" switches. Two cams are attached to the output shaft that trip these switches when the unit travels outside of the required span. For instance most actuators are set for 90° rotation and these switches are set for 110° of rotation. They simply disconnect the motor. Therefore if one of the LED drive lights is on but the actuator is not rotating it is most likely stopped by the switch.

8. ALARM

The unit will signal an alarm condition by closing dry contacts across 3 and 4. **Time Out.** If the unit fails to reach the desired set point because of valve blockage or some other mechanical failure the micro times out and closes the alarm contacts. The unit may also time out because the deadband is set too tight. The unit can't make small enough movements to resolve the set point. See deadband below.

9. DEADBAND ADJUSTMENT

The deadband is factory calibrated. However, in some instances especially if the re-set button has been used it may be necessary to re-calibrate the deadband. Deadband refers to the tolerance surrounding the set point. A tight deadband

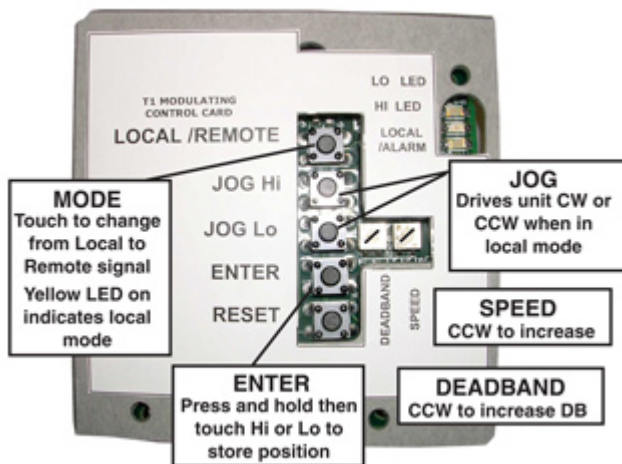

20mA is for the right two posts and 0-10Vdc is on the left two posts. See 3. Input above. Connect power to terminals 1 and 2. Power should be fused with a 1.5 amp slow-blow fuse.

4. Once the power is connected the unit will do a self-test. This will take approximately 2-3 seconds. Then

T1 MODULATING (SERVO) USE AND CARE



makes the unit move in smaller steps. A large deadband requires bigger input changes before the unit will move. If the unit is "hunting" (i.e. continuous movement back and forth) the deadband will have to be increased (CCW).

1. Disconnect the power to the unit.
2. Wait 10-15 seconds for the capacitors to "drain."
3. Rotate trimmer R22 (LEFT) CCW to increase the deadband or CW to decrease the deadband.
4. Re-connect the power.

10. SPEED CONTROL

The T1 Servo Card for DC operation has Pulse Width Modulating Control which means that the speed of the motor can be adjusted. The speed is factory set for maximum RPM. However, slower speeds can be achieved by adjusting R31. Turn R31 CW to reduce the motor RPM and increase the cycle time of the actuator.

11. SPEED CONTROL

- 1 PROBLEM: There is power to the unit but it does not respond.
 - 1.1 Verify that the correct voltage has been applied according to the ratings listed on the nameplate.
- 2 Check the wiring to verify it against the wiring schematic.
- 3 PROBLEM: Power is getting to the motor but it merely hums.
 - 3.1 Check to make sure that the proper voltage is applied and that all of the wiring connections are tight.
 - 3.2 Check to see that the unit is properly grounded.
- 4 PROBLEM: The actuator performs erratically.
 - 4.1 Check to see that the actuator is not stalling. Remove the actuator from the valve and verify the freeness of the valve operation.
 - 4.2 Check to see that the valve torque requirements are less than the rated torque output of the actuator.
 - 4.3 Check the ambient temperature rating. The AC motors are equipped with thermal protectors which cut power to the motor if excessively cycled. High temperature ambient and cycle frequencies may heat up the motor causing the thermal protector to disconnect power to the motor. Simply allow the unit to cool and it will automatically re-set.
 - 4.4 If the Reset button has been pressed the unit may need to be re-calibrated including the Deadband. Disconnect the power and wait 5 seconds. Then See '5. Set-Up' and repeat steps 4 through 7. Also, see 'Deadband Adjustment.'

- 5 PROBLEM: The Alarm LED is lit and the unit does not respond.
 - 5.1 Check to see that the unit is not experiencing one of the alarm conditions (see Alarm). If the valve is blocked or has become excessively difficult to rotate the problem will have to be remedied before continued operation. If the valve is oscillating a brake may be required or the deadband may need to be increased.
- 6 PROBLEM: The actuator drives continuously in the wrong direction.
 - 6.1 It may have been that the end of travel positions were saved in reverse. For example, say a direct acting setup is required (Lo=CW and Hi=CCW). However the Jog Lo position was saved into memory and then the Jog Hi was entered further CW. The unit will have to be re-calibrated. Disconnect the power and wait 5 seconds. Then See '5. Set-Up' and repeat steps 4 through 7. Be sure to store Jog Lo on the CW side of Jog Hi for a direct acting setup. Of course just the reverse is needed for a reverse acting unit.

11. TECHNICAL ASSISTANCE

Valvsys will be more than happy to provide technical assistance should it become necessary.

Please have the following available when calling for assistance:

1. Actuator model number
2. Actuator serial number
3. Input signal being used
4. Valve application

T1 MODULATING (SERVO) USE AND CARE



ELECTRIC ACTUATORS
 Monroe, OH 45050
 513.539.1234 ph
 513.539.2176 fx
 www.valvsys.com

